

# 2009 One Great Hour of Sharing

## *Where is your treasure?*

### Children's Activity 1: Treasure Chest



#### Purpose

To help the children understand that each of them is one of God's treasures and how One Great Hour of Sharing helps us connect to other of God's treasures

#### Materials needed

- Print the photocopy-ready drawing of an open treasure chest on page 3 on sturdy construction or cardstock paper, and make one for each child. Cut the large rectangular hole into the chest, with at least a  $\frac{3}{4}$ " edge around it, to represent the opening to the inside of the chest. It is important for the paper rim around the hole to be wide enough for the wax paper rectangles to be glued onto.
- wax paper, cut into rectangles slightly larger than the opening in the construction paper treasure chests. Have two such rectangles for each child.
- old crayons or colored candles
- scissors
- iron, on at a low heat setting and secure from the children's touching or jostling
- ironing board
- glue
- newspaper or cardboard to serve as trays

#### Activity

Talk about how God treasures each of the children present.

Give each child a wax paper rectangle with a sturdy piece of newspaper or cardboard under it to serve as a tray. Invite the children to scrape the sides of the crayons and candles to make colored wax shavings fall onto their wax paper rectangle. Talk about the colors: how different they are, and yet each is beautiful and useful when you draw a picture. What fun to have different colors to use! God's treasures—people—are like that, too: different in looks, shapes, skills, and where they live, yet God thinks each of them is beautiful, wonderful, and useful, and God needs each of them. God treasures and wants each of us!

Invite the children to experiment with placement of the shavings, although a band empty of shavings must be left around the edge of the rectangle so it will seal properly later. Perhaps some places will have only one color, some will have the colors arranged in patterns, some will have the shavings sprinkled on top of each other. Note that many colors together in the same spot can melt together to make brown. So there is some variety in color after the shavings are melted, encourage that not all the colors be put on top of each other.

Carefully bring the shaving-covered wax paper rectangles on their trays to the ironing board. You may want a sure-footed adult to do the transporting. Cover each rectangle with a second wax paper rectangle. Note where each child's art work is placed by writing his or her name on the tray, so the appropriate one can be returned to its creator. Explain that the heat from the iron represents love, similar to the warmth we feel when someone we love holds our hand or gives us a hug. Note that right now the wax shavings are distinct and separate, even if they are sprinkled on top of each other. We can see the edges where one shaving stops and another begins. Invite the children to stand close by (but not close enough to have the iron touch them!) to watch the transformation as an adult gently irons each top wax paper rectangle.

What changes do the children see taking place? (Heat melts the shavings, which begin to glide into each other.) Amplify the observations that illustrate the points below (or supply them yourself if the children don't mention them):

- The shavings are melted together now: love connects us and makes us stronger and harder to pull apart.
- Some of the colors change as shavings of different colors mix: love changes us, making us more beautiful on the inside.
- When a shaving or a person is warmed by love, it can reach out further than it could before and touch others in a gentle and beautiful way.

Just like the iron traveled over the rectangles and delivered heat to the wax shavings, One Great Hour of Sharing offerings travel throughout the world to deliver love between people who may live far apart. Sometimes it is the warmth of a blanket or a tent, the warmth of pleasure that comes from getting to go to school and having a book to read, the warmth of a cooked meal, or the warmth of knowing that someone cares when you are having a tough time.

When the wax papers are sufficiently cool, the children glue their colored rectangle onto the back of their treasure chest, covering the pre-cut hole, and write their name on the back of the chest. Suggest the children turn their art work over and see how it looks like a chest filled with jewels and treasure. Invite them to take their treasure chest home to remind them:

- They are one of God's dearly loved treasures.
- Through One Great Hour of Sharing, we can share God's love with other people and be touched by others whom God treasures.
- Together, all the people of the earth make a beautiful treasure chest for God.



sharing resources. changing lives.

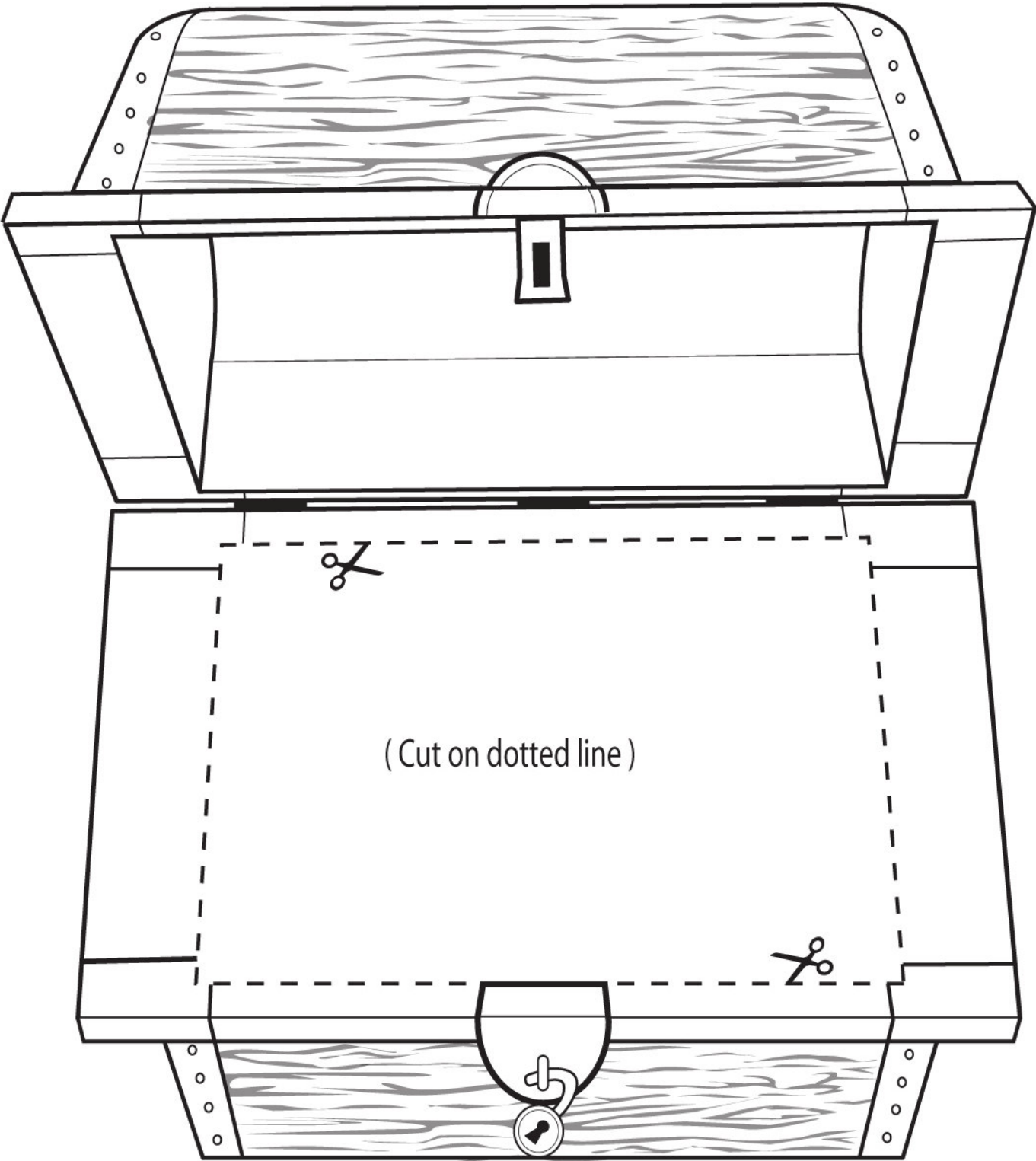

## Children's Activity 2: Treasured in the Heart

This activity can also be adapted for use with youth and intergenerational groups.

### Purpose

To guide children in thinking of ways people need help in specific situations and to reinforce that One Great Hour of Sharing helps in those ways

### Materials needed

Heart shapes cut from compressed sponges, two for each child and the leader. Compressed sponges are available at some craft and art supply stores and through web sites such as <http://colorwheelco.com>. (The children may enjoy being given any remaining sponge scraps to cut and play with later.)

### Activity

The leader reminds the children that God considers each person to be a treasure and has even made us in God's own image. One aspect of being made in God's image is the ability to love and care for others. Love is often symbolized by a heart-shape. The leader then shows one of the hearts.

Next, describe a situation or area where we use One Great Hour of Sharing money. [The children's activity map or the bulletin insert will be helpful with this information.] The leader asks, "How could we show caring for someone in that situation? What specific ways might that person need help?" For example, a family whose community is destroyed by a cyclone might need clean water, food, temporary shelter, help rebuilding/repairing their home, clothing, blankets, and medical care. The leader guides the answers to include services that One Great Hour of Sharing provides, and says, "We help make that happen! We provide those very things by giving to One Great Hour of Sharing." The leader describes several more situations, asking the same questions and guiding the conversation to explain how One Great Hour of Sharing helps.

The leader then passes around the heart-shape and asks the children to describe how this heart feels (dry, thin, and hard). The heart is a symbol for love, but this heart doesn't feel very lovely. After placing the heart on a clear bowl or plate that can catch the overflow while still keeping the heart visible, the leader pours water on the heart. The sponge will dramatically expand and soften before the children's eyes. Sharing God's love by caring for someone does our hearts good, just like the water did this sponge good. What a difference it makes!

Money is sometimes described as "liquid love," because it can go where we cannot, just like water can flow into tiny places our bodies can't fit into and can join the ocean and travel to places far away where we may never go. Our gifts of money to One Great Hour of Sharing will take our love and caring to people in need who may live very far away. And look how our gifts will affect them. The leader squeezes water from the already wet heart onto the second dry heart, which expands and softens. People who receive help from One Great Hour of Sharing will know in their hearts that some Christians care very much that they are having a tough time and have acted to help them.

Close by singing "Jesus Loves the Little Children" (lyrics and tune at <http://cyberhymnal.org/html/j/e/jesloves.htm>) and with prayer. Give each child two heart-shaped sponges as a reminder of the difference made in our and others' lives by giving to One Great Hour of Sharing.